



ULTRA SEAT CORPORATION

## Ultra 5200 Series



### Features:

- ◆ Heavy duty mechanical suspension
- ◆ Advanced ergonomic contoured cushions with adjustable back rest
- ◆ Double locking slide rails between suspension and seat
- ◆ Adjustable lumbar
- ◆ Weight adjustment
- ◆ 3" height adjustment
- ◆ Includes tethers
- ◆ 5200 black vinyl (waterproof) - 850-72
- ◆ 5200 gray fabriform fabric - 850-75

### Options:

- ◆ Adjustable fabric headrest - 850-20
- ◆ Adjustable armrests 3" R/H - 850-39R
- ◆ Adjustable armrests 3" L/H - 850-39L
- ◆ Retractable seat belt 2" - 810-65
- ◆ Retractable seat belt 3" - 810-67
- ◆ Retractable seat belt 2" with 16" extension - 810-69
- ◆ "Z" bar mounting brackets - 810-59
- ◆ Mounting Plate - 850-59
- ◆ 4" pedestal base - 830-71
- ◆ 7" pedestal base - 830-70

### Replacement Seat Covers complete with Foam:

- ◆ Black vinyl seat cover - 850-50VSC
- ◆ Black vinyl back cover - 850-50VBC
- ◆ Gray fabriform fabric seat cover - 850-50FSC
- ◆ Gray fabriform fabric back cover - 850-50FBC

Call Us Today  
Phone: 1-800-667-7328  
Fax: 1-888-667-7328



# ULTRA SEAT CORPORATION

## Ultra

### 5200 Series - Dimensions

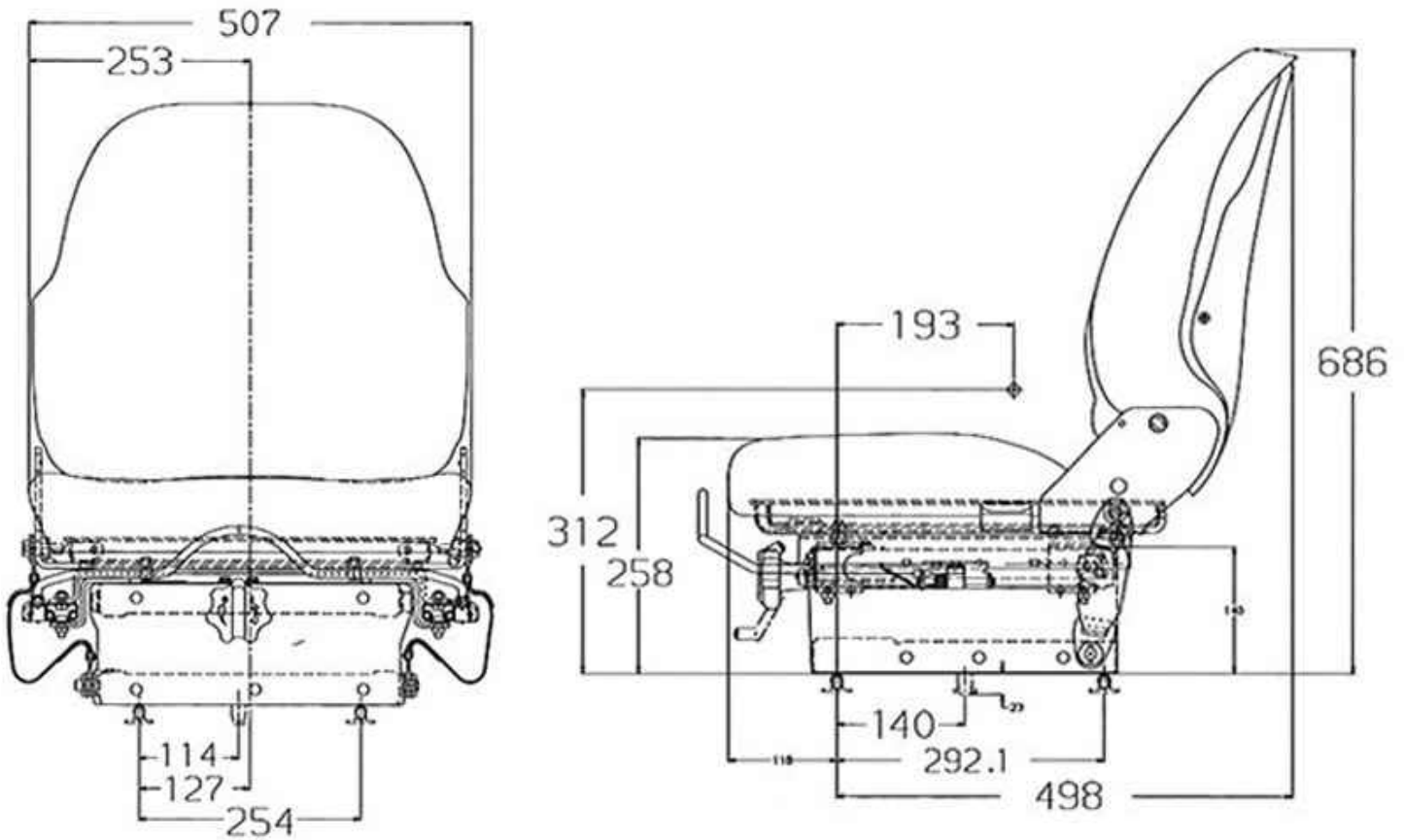

**Note: Mounting Plate & "Z" Bar mounting brackets accomodate a wide range of bolt patterns.  
Dimensions shown at mid-suspension stroke.**

5200 Series - Mechanical - Weight 100 lbs.

Call Us Today  
 Phone: 1-800-667-7328  
 Fax: 1-888-667-7328

Sold By: